

AIR PRESSURE SENSING SWITCH  
WITH ADJUSTABLE SET POINT  
(SET POINT RANGE: 0.05" WC TO 2.0" WC)



# MODEL AFS-262-112

## APPLICATION

Model AFS-262-112 is a general purpose proving switch designed for HVAC and Energy Management applications. It can be used to sense positive, negative, or differential air pressure.

## DESCRIPTION & OPERATION

The plated housing contains a diaphragm, a calibration spring and a snap-acting SPDT switch. The convenient barbed sample line connections located on each side of the diaphragm accept flexible tubing.

The enclosure cover guards against accidental contact with the live switch terminal screws and the set point adjusting screw. The enclosure cover accepts a 1/2" conduit connection.

## MOUNTING (FIGURE 1)

Select a mounting location that is free from vibration. Mount the AFS-262-112 with the diaphragm in any vertical plane in order to obtain the lowest specified operating set point. Surface mount via the two 3/16" diameter holes in the integral mounting bracket. The mounting holes are 3-7/8" apart.

## AIR SAMPLING CONNECTION (FIGURE 2)

The AFS-262-112 is designed to accept flexible tubing by means of barbed 1/4" slip-on connections. For sample lines of up to 10 feet, 1/4" OD tubing is acceptable. For lines up to 20 feet, use 1/4" ID tubing.

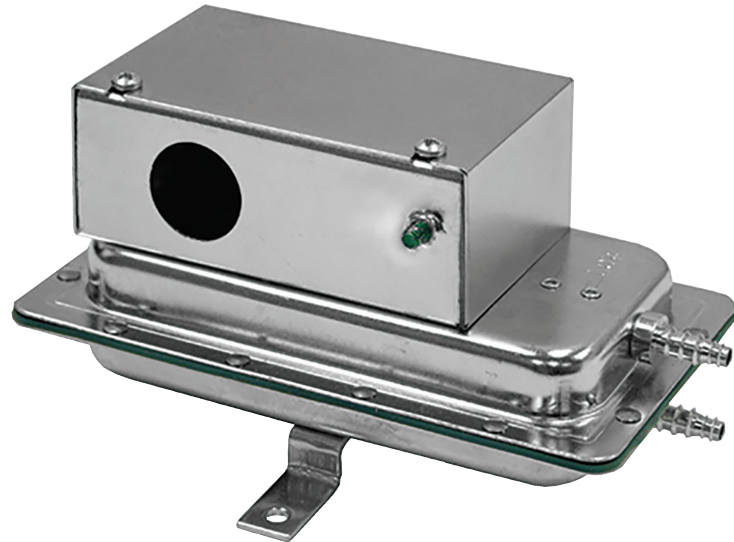
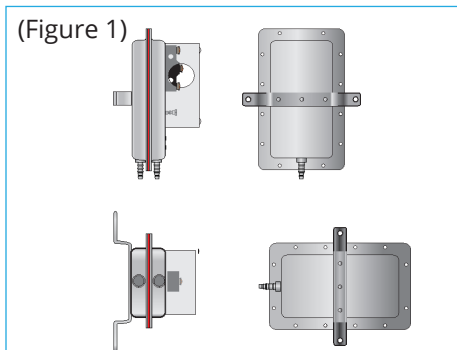

Locate the sampling probe a minimum of 1.5 duct diameters downstream from the air source. Install the sampling probe as close to the center of the airstream as possible.

Refer to Figure 2 to identify the high pressure inlet (H) and the low pressure inlet (L). Select one of the following five application options, and connect the sample lines as recommended.

**POSITIVE PRESSURE ONLY:** Connect the sample line to inlet H; inlet L remains open to the atmosphere.

**NEGATIVE PRESSURE ONLY:** Connect the sample line to inlet L; inlet H remains open to the atmosphere.

**TWO NEGATIVE SAMPLES:** Connect the higher negative sample to inlet L. Connect the lower negative sample to inlet H.

**TWO POSITIVE SAMPLES:** Connect the higher positive sample to inlet H. Connect the lower positive sample to inlet L.

**ONE POSITIVE AND ONE NEGATIVE:** Connect the positive sample to inlet H. Connect the negative sample to inlet L.

## ELECTRICAL CONNECTIONS (FIGURES 3 & 4)

Before pressure is applied to the diaphragm, the switch contacts will be in the normally closed (NC) position. The snap switch has screw top terminals with cup washers. Wire alarm and control applications as shown in Figure 4.

## FIELD ADJUSTMENT

The adjustment range of an AFS-262-112 is 0.05 + 0.035/-0.005" wc to 2.0" wc. To adjust the set point, turn the adjusting screw counterclockwise until motion has stopped. Next, turn the screw 4 complete turns clockwise to engage the spring. From this point, the next ten turns will be used for the actual calibration. Each full turn represents approximately 0.2" wc

Please note: To properly calibrate an air switch, use a digital manometer or other measuring device to confirm the actual set point.

(Figure 2)

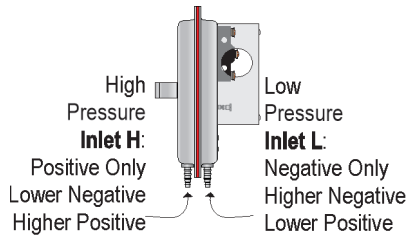

(Figure 3)

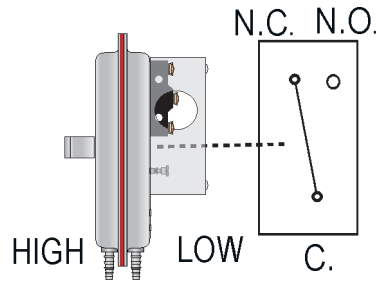

(Figure 4)

To prove excessive air flow or pressure:

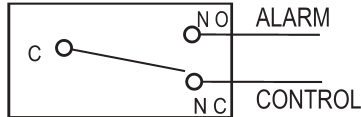

To prove insufficient air flow or pressure:

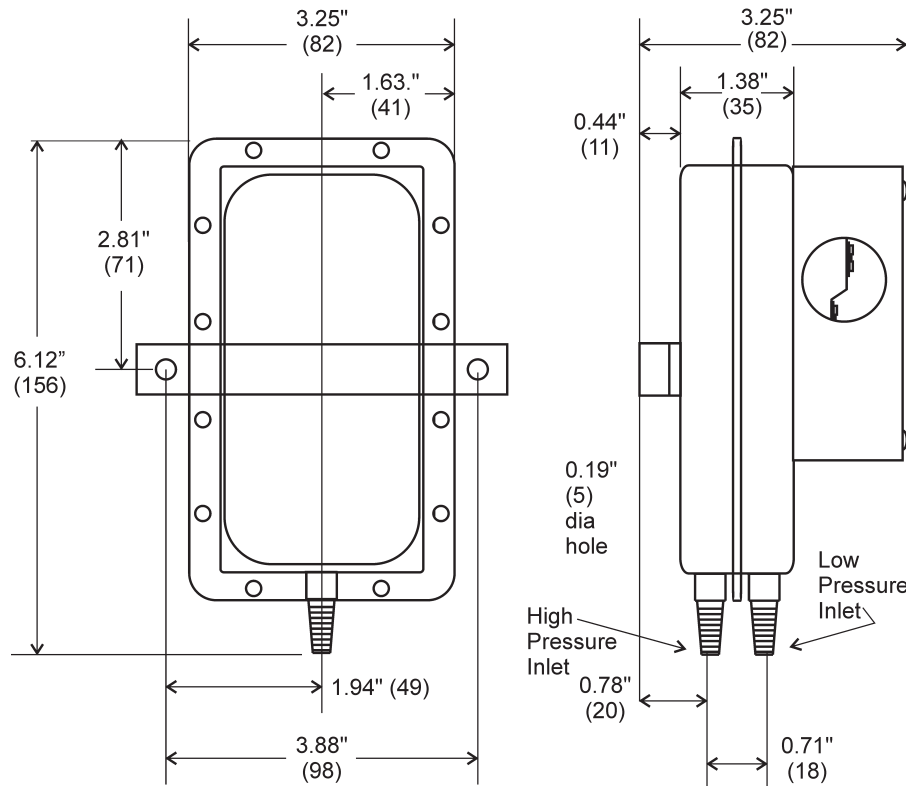
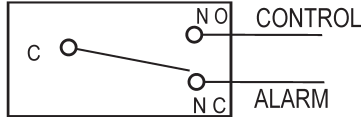

Nominal Dimensions in Inches (Millimeters)

**SPECIFICATIONS**  
**MODEL AFS-262-112**  
**AIR PRESSURE SENSING SWITCH**  
**WITH ADJUSTABLE SET POINT**



**Mounting Position:**

Mount with the diaphragm in any vertical plane

**Set Point Range:**

0.05 +0.035/-0.005" wc to 2.0" wc

**Field Adjustable "Operate Range":**

0.07" wc to 2.0" wc

**Field Adjustable "Release Range":**

0.04" wc to 1.9" wc

**Approximate Switching Differential:**

Progressive, increasing from 0.02±0.01" wc at minimum set point to approximately 0.1" wc at maximum set point

**Measured Media:**

Air, or combustion by-products that will not degrade silicone

**Maximum Pressure:** ½ psi (0.03 bar)

**Operating Temperature Range:**

-40 °F to 180 °F (-40 °C to 82 °C)

**Life:**

100,000 cycles minimum at ½ psi maximum pressure each cycle and at maximum rated electrical load

**Electrical Rating:**

300 VA pilot duty at 115 to 277 V ac, 15 Amps noninductive to 277 V ac, 60 Hz.

**Contact Arrangement:** SPDT

**Electrical Connections:**

Screw-type terminals with cup washers

**Conduit Opening:**

7/8" diameter opening accepts ½" conduit

**Sample Line Connections:**

Two barbed ¼" connectors accept 1/8" thru ¼" ID flexible plastic tubing

**Approval:** UL, FM, CSA, CE

**Shipping Weight:** 1.2 lbs.

**Accessories:**

- Sample line probes
- Orifice plugs (pulsation dampers)